



RAZER FUJIN HEADREST

MASTER GUIDE

Boost your level of breathable comfort with a key accessory for the Razer Fujin series. Made from the same durable mesh material, the **Razer Fujin Headrest** features a 3D contoured design that provides enhanced ergonomics for your head and neck—all with the simplicity of a one-step installation.

CONTENTS

1. ASSEMBLY.....	3
2. USAGE.....	4
3. LET'S GET YOU COVERED.....	5
4. SAFETY AND MAINTENANCE.....	6
5. LEGALESE.....	7

1. ASSEMBLY

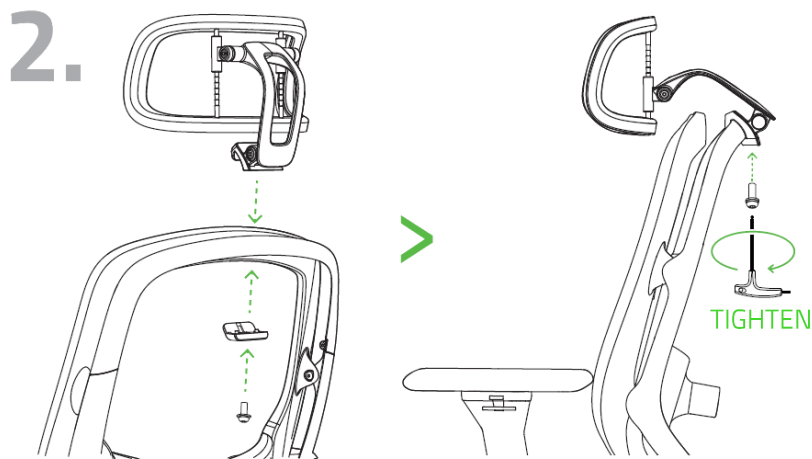
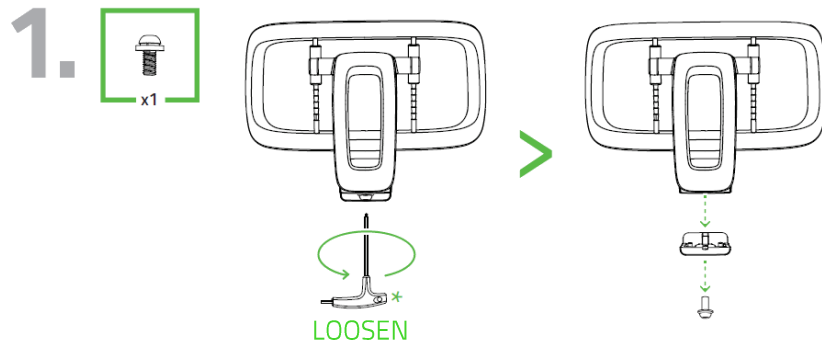

*Screwdriver from Razer Fujin Headrest

2. USAGE

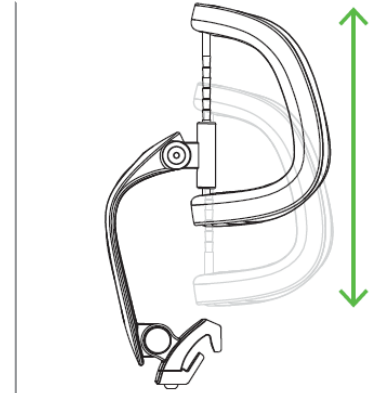
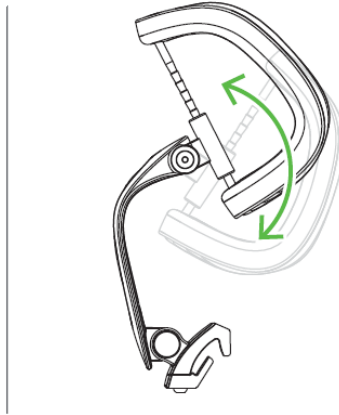
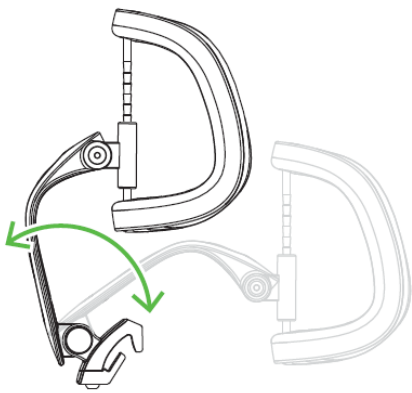

3. LET'S GET YOU COVERED

You've got a great product on your hands, complete with a limited warranty coverage. Now maximize its potential and score exclusive Razer benefits by registering at razerid.razer.com

Warranty Length:



5 years warranty for nylon frame, mechanisms & moving parts.

(not including wear and tear)



1-year warranty for upholstery / foam materials / surfaces.

Got a question? Ask the Razer Support Team at support.razer.com

4. SAFETY AND MAINTENANCE

SAFETY GUIDELINES

This product is intended as a piece of furniture designed to accommodate one sitting or reclining person. In order to achieve maximum safety while using your Razer Fujin Headrest, we suggest that you adopt the following guidelines:

- Be mindful of your hand, hair, or finger placement when adjusting the sliders and levers.
- To prevent color from fading, upholstery from drying, and plastic parts from cracking; avoid exposure to high heat such as a radiator or a fireplace; and keep out of direct sunlight.
- To prevent damage to the upholstery, keep away from sharp objects or pets with claws and teeth.
- To avoid accidents, do not use unless all bolts, screws, and knobs are firmly secured. Check all bolts, screws, and knobs at least every 90 days, and make sure they are properly tightened.

Should you have problems operating the Razer Fujin Headrest properly and troubleshooting does not work, contact the Razer hotline or go to support.razer.com for assistance. If any parts are missing, broken, damaged, or worn; and your headrest is still covered by warranty, we will provide you with replacement parts. Do not use your headrest until the parts have been repaired or replaced.

MAINTENANCE

The Razer Fujin Headrest requires minimum maintenance to keep it in optimum condition. Constant exposure to friction, skin, and bodily fluids can degrade the materials over time. We recommend that you clean the headrest once a month using a soft or microfiber cloth with a bit of warm water to prevent perspiration and dirt buildup. Immediately clean up spills to avoid stains and completely air dry before using the headrest again. Do not use soap, harsh cleaning agents, or abrasives to avoid damaging the headrest.

5. LEGALESE

COPYRIGHT AND INTELLECTUAL PROPERTY INFORMATION

©2025 Razer Inc. All rights reserved. Razer, the triple-headed snake logo, Razer logo, and “For Gamers. By Gamers.”, are trademarks or registered trademarks of Razer Inc. and/or affiliated companies in the United States or other countries. All other trademarks are the property of their respective owners.

Razer Inc. (“Razer”) may have copyright, trademarks, trade secrets, patents, patent applications, or other intellectual property rights (whether registered or unregistered) concerning the product in this guide. Furnishing of this guide does not give you a license to any such copyright, trademark, patent or other intellectual property right. The Razer Fujin Headrest (the “Product”) may differ from pictures whether on packaging or otherwise. Razer assumes no responsibility for such differences or for any errors that may appear. Information contained herein is subject to change without notice.

LIMITED PRODUCT WARRANTY

For the latest and current terms of the Limited Product Warranty, please visit [razer.com/warranty](https://www.razer.com/warranty).

LIMITATION OF LIABILITY

Razer shall in no event be liable for any lost profits, loss of information or data, special, incidental, indirect, punitive or consequential or incidental damages, arising in any way out of distribution of, sale of, resale of, use of, or inability to use the Product. In no event shall Razer’s liability exceed the retail purchase price of the Product.

GENERAL

These terms shall be governed by and construed under the laws of the jurisdiction in which the Product was purchased. If any term herein is held to be invalid or unenforceable, then such term (in so far as it is invalid or unenforceable) shall be given no effect and deemed to be excluded without invalidating any of the remaining terms. Razer reserves the right to amend any term at any time without notice.