



# RAZER BLUE SCREEN

MASTER GUIDE

# CONTENTS

1. WHAT'S INSIDE .....	2
2. LET'S GET YOU COVERED .....	3
3. SETTING UP YOUR RAZER BLUE SCREEN .....	4
4. SAFETY AND MAINTENANCE .....	5
5. LEGALESE.....	6

---

## 1. WHAT'S INSIDE

- Razer Blue Screen

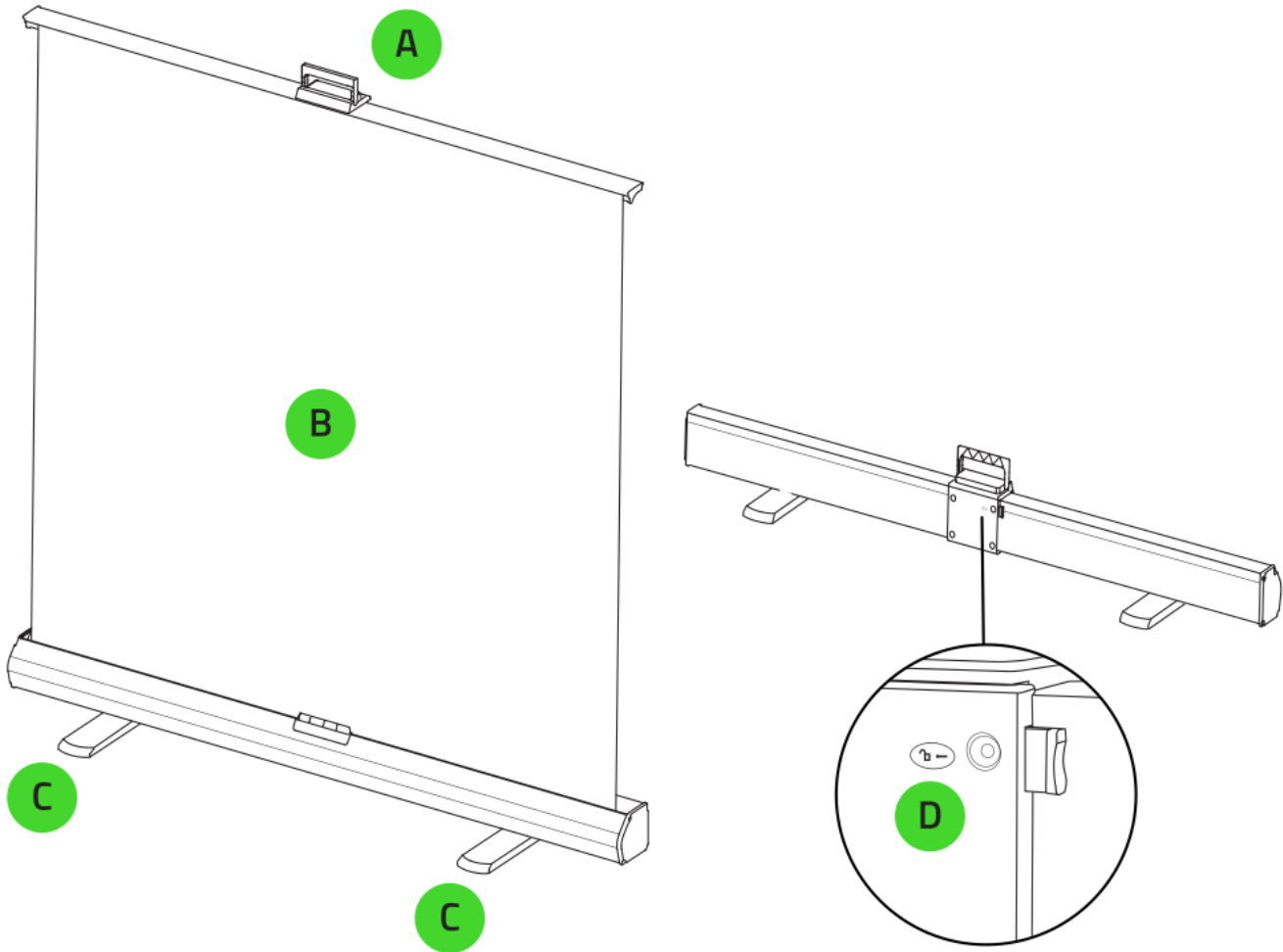

- A. Carrying handle
- B. Height-adjustable 94" screen
- C. Quick-deployable feet
- D. Safety lock button

- Important product information guide

---

## 2. LET'S GET YOU COVERED



Register your product and score exclusive benefits  
[razerid.razer.com/warranty](https://razerid.razer.com/warranty)

*Your product's  
serial number can  
be found here.*

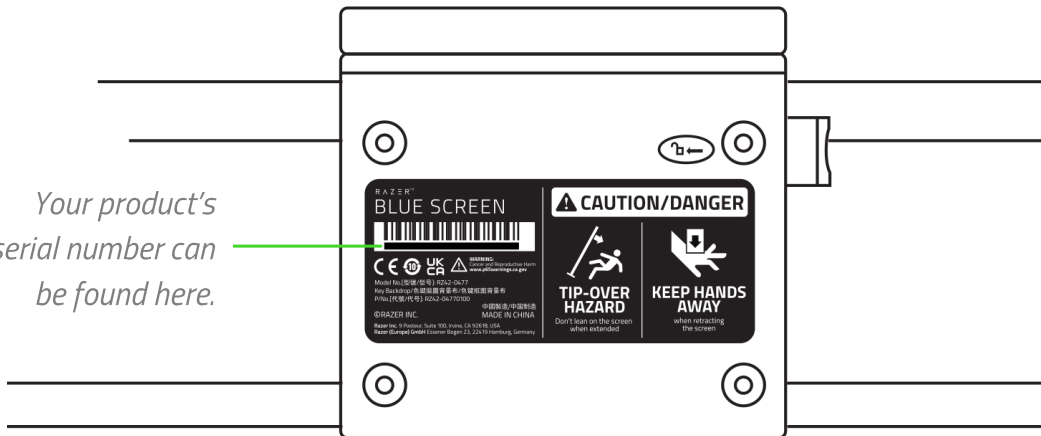

---

## 3. SETTING UP YOUR RAZER BLUE SCREEN

### EXTENDING THE SCREEN

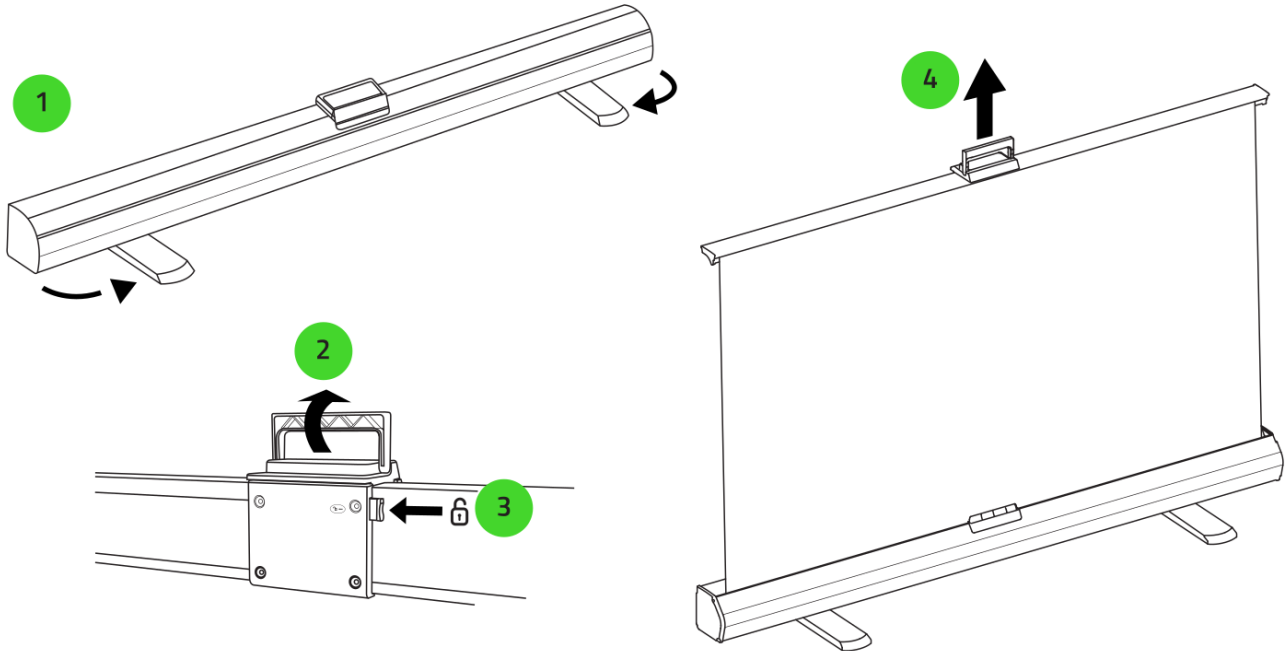

### RETRACTING THE SCREEN

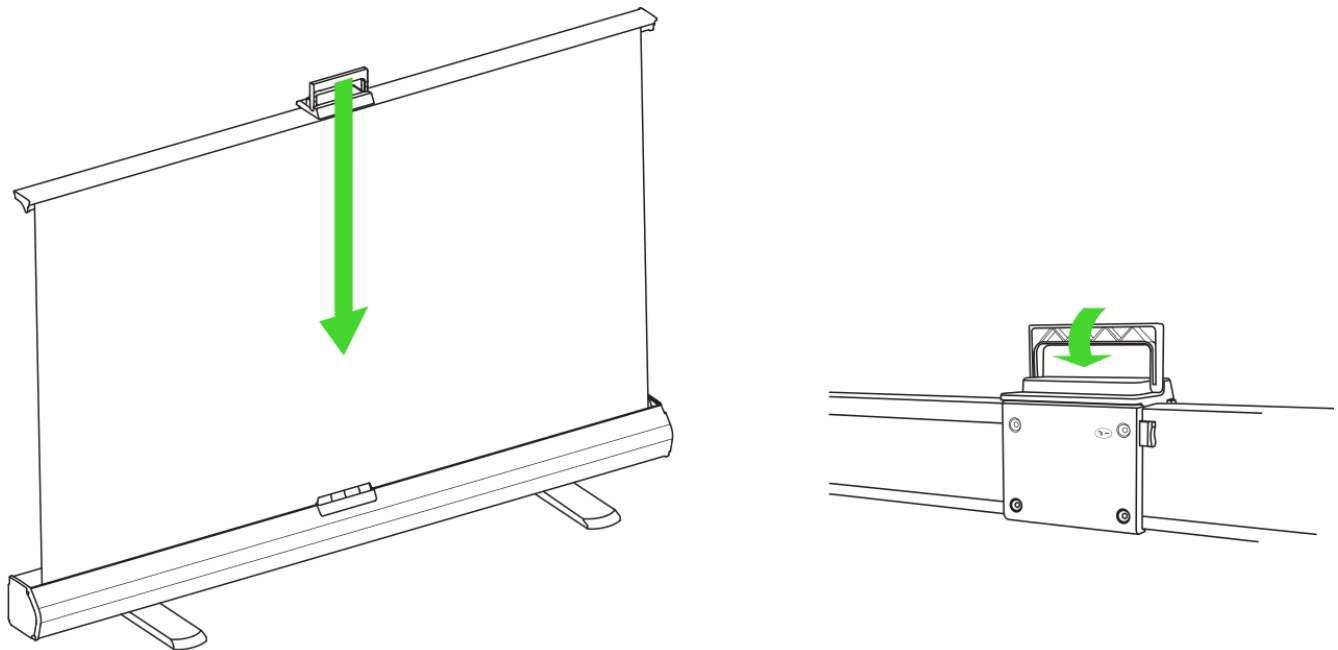

**!** When retracting the screen, make sure there are no obstructions on both ends and only push down from the carrying handle to avoid injury.

---

## 4. SAFETY AND MAINTENANCE

### SAFETY GUIDELINES

To achieve maximum safety while using your Razer Blue Screen, we suggest that you adopt the following guidelines:

- Should you have trouble operating the device correctly and troubleshooting does not work, contact the Razer hotline or go to [support.razer.com](https://support.razer.com) for support.
- Always position the screen on a flat and stable surface.
- When extending or retracting the screen, always use the carrying handle and practice caution to avoid injury.
- When extended, don't lean on or attach any items on (or on top of) the screen.
- When not in use and retracted, tuck each foot underneath the base and store the device horizontally.
- Don't expose the screen to direct sunlight for extended periods.
- Don't position and extend the screen in areas with strong air currents, as these may cause the screen to topple or affect the screen's appearance during use.
- When retracting the screen, make sure there are no obstructions on both ends and only push down from the carrying handle to avoid injury.

### MAINTENANCE AND USE

The Razer Blue Screen requires minimum maintenance to keep it in optimum condition. Once a month, we recommend you lightly wipe the screen using a soft cloth to prevent dirt buildup. Don't use soap or harsh cleaning agents.

---

## 5. LEGALESE

### **COPYRIGHT AND INTELLECTUAL PROPERTY INFORMATION**

©2025 Razer Inc. All rights reserved. Razer, the triple-headed snake logo, Razer logo, “For Gamers. By Gamers.”, and “Razer Chroma” logo are trademarks or registered trademarks of Razer Inc. or affiliated companies in the United States and other countries. All other trademarks are the property of their respective owners.

Razer Inc. (“Razer”) may have copyright, trademarks, trade secrets, patents, patent applications, or other intellectual property rights (whether registered or unregistered) concerning the product in this guide. Furnishing of this guide does not give you a license to any such copyright, trademark, patent or other intellectual property right. The Razer Blue Screen (the “Product”) may differ from pictures whether on packaging or otherwise. Razer assumes no responsibility for such differences or for any errors that may appear. Information contained herein is subject to change without notice.

### **LIMITED PRODUCT WARRANTY**

For the latest and current terms of the Limited Product Warranty, please visit [razer.com/warranty](https://razer.com/warranty).

### **LIMITATION OF LIABILITY**

Razer shall in no event be liable for any lost profits, loss of information or data, special, incidental, indirect, punitive or consequential or incidental damages, arising in any way out of distribution of, sale of, resale of, use of, or inability to use the Product. In no event shall Razer’s liability exceed the retail purchase price of the Product.

### **GENERAL**

These terms shall be governed by and construed under the laws of the jurisdiction in which the Product was purchased. If any term herein is held to be invalid or unenforceable, then such term (in so far as it is invalid or unenforceable) shall be given no effect and deemed to be excluded without invalidating any of the remaining terms. Razer reserves the right to amend any term at any time without notice.